

 mb air systems ltd

**FiltAir-Receiver®**

*Air Receivers will never be the same again!*



## **FiltAir-Receiver**<sup>®</sup>

(Patent Pending)

### **What does it do?**

- Provides compressed air storage.
- Significantly reduces the compressed air and contaminants' velocity.
- Simplifies contaminant separation.
- Provides downstream compressed air quality similar to general-purpose filters.
- Achieves negligible pressure drop across the unit.
- Reduces energy costs.
- Achieves longer separator element life, typically more than 5 times that of a general-purpose filter.
- Reduces maintenance costs.
- Reduces installation costs.
- Reduces disposal costs.
- FiltAir-Receiver<sup>®</sup> reduces your total costs, even the upfront costs!

### **What does it do for your business?**

- FiltAir-Receiver<sup>®</sup> increases your profitability.

***Air Receivers will never be the same.***



## **Background:**

### **Air Receivers:**

Air Receivers have been one of the most under-rated pieces of equipment in a compressed air system. In virtually all industrial applications compressed air demand varies. Air storage vessels in a compressed air system balance the flow of air to the service lines and compressor controls.

It has the following main functions:

- Acts as a reservoir that can be called upon to meet intermittent demands that are in excess of the compressor's capacity.
- Prevents the compressor cycling too frequently.
- Precipitates condensate, which might be present in the air.
- Reduces the air velocity through the vessel.

### **General Purpose Filters:**

Filtration is required to remove contaminants from the compressed air. General Purpose Filters are fitted before air dryers and often after an air receiver.

However in carrying out it's function the filter element will become increasingly blocked which can cause reliability problems, compromising product quality and increased energy consumption through increased pressure drops. Filter elements should be regularly checked as part of a plant maintenance programme and replaced when the pressure differential approaches 0.4 barg or sooner. Most filter manufacturers recommend that filter elements should be replaced every 6 months.

A 0.4 barg pressure drop equates to 3% increase in air compressor energy consumption!

### **Innovation:**

#### **FiltAir-Receiver (Patent Pending):**

**FiltAir-Receiver** combines the benefit of air storage and general purpose filtration in one simple solution. The unit is fitted with an integral separator element, which has been used successfully in a rotary screw air compressor's separator tank design for almost 30 years.

The separator element, located at the discharge point of the vessel, is a moulded fibreglass two stage reinforced element. The outer layer of the element has a 0.5 micron rating and is designed to remove debris and contaminant from the compressed air as it passes through the element.

Compressed air velocity, including the velocity of contaminants in an air storage vessel, is significantly reduced. Gravity also reduces the contaminants' kinetic energy as they approach the separator element. This occurrence enables the separation to take place with minimum effort and consequently with an almost negligible pressure drop. **FiltAir-Receiver** can easily achieve an energy saving of 3% compared to a conventional system requiring filter element replacement at an average pressure differential of 0.4 barg.

This simple separation results in much longer separator element life. Typically only one element change over a 5 year period will be required. This compares with 5 element changes in a conventional system.

Furthermore **FiltAir-Receiver** can provide additional protection and contaminant separation in an excessive oil carry over situation preventing the need for additional equipment such as oil eliminators.

**So simple!**

***Air Receivers will never be the same.***



**Cost Comparison - Minimum Measure**

**37 KW Air Compressor  
6 m3/min - 7 barg**

<b>Conventional System</b>	Year 1	10 Years
1000 Litres Air Receiver	£1,600	£1,600
Zero Loss Drain	£300	£300
General Purpose Filter	£500	£500
Zero Loss Drain	£135	£135
Filter Element	£120	£1,200
<b>Sub Total</b>	<b>£2,655</b>	<b>£3,735</b>
Energy relating to 0.4 barg PD	£533	£5,328
<b>Total</b>	<b>£3,188</b>	<b>£9,063</b>

**55 KW Air Compressor  
10 m3/min - 7 barg**

<b>Conventional System</b>	Year 1	10 Years
2000 Litres Air Receiver	£2,200	£2,200
Zero Loss Drain	£300	£300
General Purpose Filter	£600	£600
Zero Loss Drain	£135	£135
Filter Element	£130	£1,300
<b>Sub Total</b>	<b>£3,365</b>	<b>£4,535</b>
Energy relating to 0.4 barg PD	£792	£7,920
<b>Total</b>	<b>£4,157</b>	<b>£12,455</b>

<b>FiltAir-Receiver</b>	Year 1	10 Years
FiltAir-Receiver 1000	£3,290	£3,290
Element	£0	£300
<b>Total</b>	<b>£3,290</b>	<b>£3,590</b>
<b>Savings over 10 years</b>		<b>£5,473</b>

<b>FiltAir-Receiver</b>	Year 1	10 Years
FiltAir-Receiver 2000	£4,565	£4,565
Element	£0	£300
<b>Total</b>	<b>£4,565</b>	<b>£4,865</b>
<b>Savings over 10 years</b>		<b>£7,590</b>

Energy cost relating to 0.4 barg pressure differential is based on the unit operating in average at 80% load, 6000 hours per year & @ £0.10 per KW/H.



**Cost Comparison - Minimum Measure**

**90 KW Air Compressor  
16 m3/min - 7 barg**

<b>Conventional System</b>	<b>Year 1</b>	<b>10 Years</b>
3000 litres Air Receiver	£3,250	£3,250
Zero Loss Drain	£300	£300
General Purpose Filter	£1,000	£1,000
Zero Loss Drain	£135	£135
Filter Element	£225	£2,250
<b>Sub Total</b>	<b>£4,910</b>	<b>£6,935</b>
Energy relating to 0.4 barg PD	£1,296	£12,960
<b>Total</b>	<b>£6,206</b>	<b>£19,895</b>

**160 KW Air Compressor  
28 m3/min - 7 barg**

<b>Conventional System</b>	<b>Year 1</b>	<b>10 Years</b>
5000 litres Air Receiver	£4,000	£4,000
Zero Loss Drain	£300	£300
General Purpose Filter	£1,400	£1,400
Zero Loss Drain	£135	£135
Filter Element	£350	£3,500
<b>Sub Total</b>	<b>£6,185</b>	<b>£9,335</b>
Energy relating to 0.4 barg PD	£2,304	£23,040
<b>Total</b>	<b>£8,489</b>	<b>£32,375</b>

<b>FiltAir-Receiver</b>	<b>Year 1</b>	<b>10 Years</b>
FiltAir-Receiver 3000	£6,125	£6,125
Element	£0	£650
<b>Total</b>	<b>£6,125</b>	<b>£6,775</b>
<b>Savings over 10 years</b>		<b>£13,120</b>

<b>FiltAir-Receiver</b>	<b>Year 1</b>	<b>10 Years</b>
FiltAir-Receiver 5000	£7,490	£7,490
Element	£0	£650
<b>Total</b>	<b>£7,490</b>	<b>£8,140</b>
<b>Savings over 10 years</b>		<b>£24,235</b>

Energy cost relating to 0.4 barg pressure differential is based on the unit operating in average at 80% load, 6000 hours per year & @ £0.10 per KW/H.



### Cost Comparison - Maximum Measure

#### 37 KW Air Compressor 6 m3/min - 7 barg

Conventional System	Year 1	10 Years
1000 litres Air Receiver	£1,600	£1,600
Zero Loss Drain	£300	£300
General Purpose Filter	£500	£500
Zero Loss Drain	£135	£135
Filter Element	£120	£1,200
Oil Eliminator	£2,900	£2,900
Oil Eliminator Element	£0	£1,850
Zero Loss Drain	£135	£135
<b>Sub Total</b>	<b>£5,690</b>	<b>£8,620</b>
Energy relating to 0.4 barg PD	£972	£9,724
<b>Total</b>	<b>£6,662</b>	<b>£18,344</b>

FiltAir-Receiver	Year 1	10 Years
FiltAir-Receiver 1000	£3,290	£3,290
Element	£0	£300
<b>Total</b>	<b>£3,290</b>	<b>£3,590</b>
<b>Savings over 10 years</b>		<b>£14,754</b>

#### 55 KW Air Compressor 10 m3/min - 7 barg

Conventional System	Year 1	10 Years
2000 litres Air Receiver	£2,200	£2,200
Zero Loss Drain	£300	£300
General Purpose Filter	£600	£600
Zero Loss Drain	£135	£135
Filter Element	£130	£1,300
Oil Eliminator	£3,200	£3,200
Oil Eliminator Element	£0	£2,000
Zero Loss Drain	£135	£135
<b>Sub Total</b>	<b>£6,700</b>	<b>£9,870</b>
Energy relating to 0.4 barg PD	£1,445	£14,454
<b>Total</b>	<b>£8,145</b>	<b>£24,324</b>

FiltAir-Receiver	Year 1	10 Years
FiltAir-Receiver 2000	£4,565	£4,565
Element	£0	£300
<b>Total</b>	<b>£4,565</b>	<b>£4,865</b>
<b>Savings over 10 years</b>		<b>£19,459</b>

Energy cost relating to 0.4 barg pressure differential is based on the unit operating @ full load, 8760 hours per year & @ £0.10 per KW/H.



### Cost Comparison - Maximum Measure

#### 90 KW Air Compressor 16 m3/min - 7 barg

Conventional System	Year 1	10 Years
3000 litres Air Receiver	£3,250	£3,250
Zero Loss Drain	£300	£300
General Purpose Filter	£1,000	£1,000
Zero Loss Drain	£135	£135
Filter Element	£225	£2,250
Oil Eliminator	£3,200	£3,200
Oil Eliminator Element	£0	£2,000
Zero Loss Drain	£135	£135
<b>Sub Total</b>	<b>£8,245</b>	<b>£12,270</b>
Energy relating to 0.4 barg PD	£2,365	£23,652
<b>Total</b>	<b>£10,610</b>	<b>£35,922</b>

FiltAir-Receiver	Year 1	10 Years
FiltAir-Receiver 3000	£6,125	£6,125
Element	£0	£650
<b>Total</b>	<b>£6,125</b>	<b>£6,775</b>
<b>Savings over 10 years</b>		<b>£29,147</b>

#### 160 KW Air Compressor 28 m3/min - 7 barg

Conventional System	Year 1	10 Years
5000 litres Air Receiver	£4,000	£4,000
Zero Loss Drain	£300	£300
General Purpose Filter	£1,400	£1,400
Zero Loss Drain	£135	£135
Filter Element	£350	£3,500
Oil Eliminator	£5,400	£5,400
Oil Eliminator Element	£0	£3,000
Zero Loss Drain	£135	£135
<b>Sub Total</b>	<b>£11,720</b>	<b>£17,870</b>
Energy relating to 0.4 barg PD	£4,205	£42,048
<b>Total</b>	<b>£15,925</b>	<b>£59,918</b>

FiltAir-Receiver	Year 1	10 Years
FiltAir-Receiver 5000	£7,490	£7,490
Element	£0	£650
<b>Total</b>	<b>£7,490</b>	<b>£8,140</b>
<b>Savings over 10 years</b>		<b>£51,778</b>

Energy cost relating to 0.4 barg pressure differential is based on the unit operating @ full load, 8760 hours per year & @ £0.10 per KW/H.

BEFORE

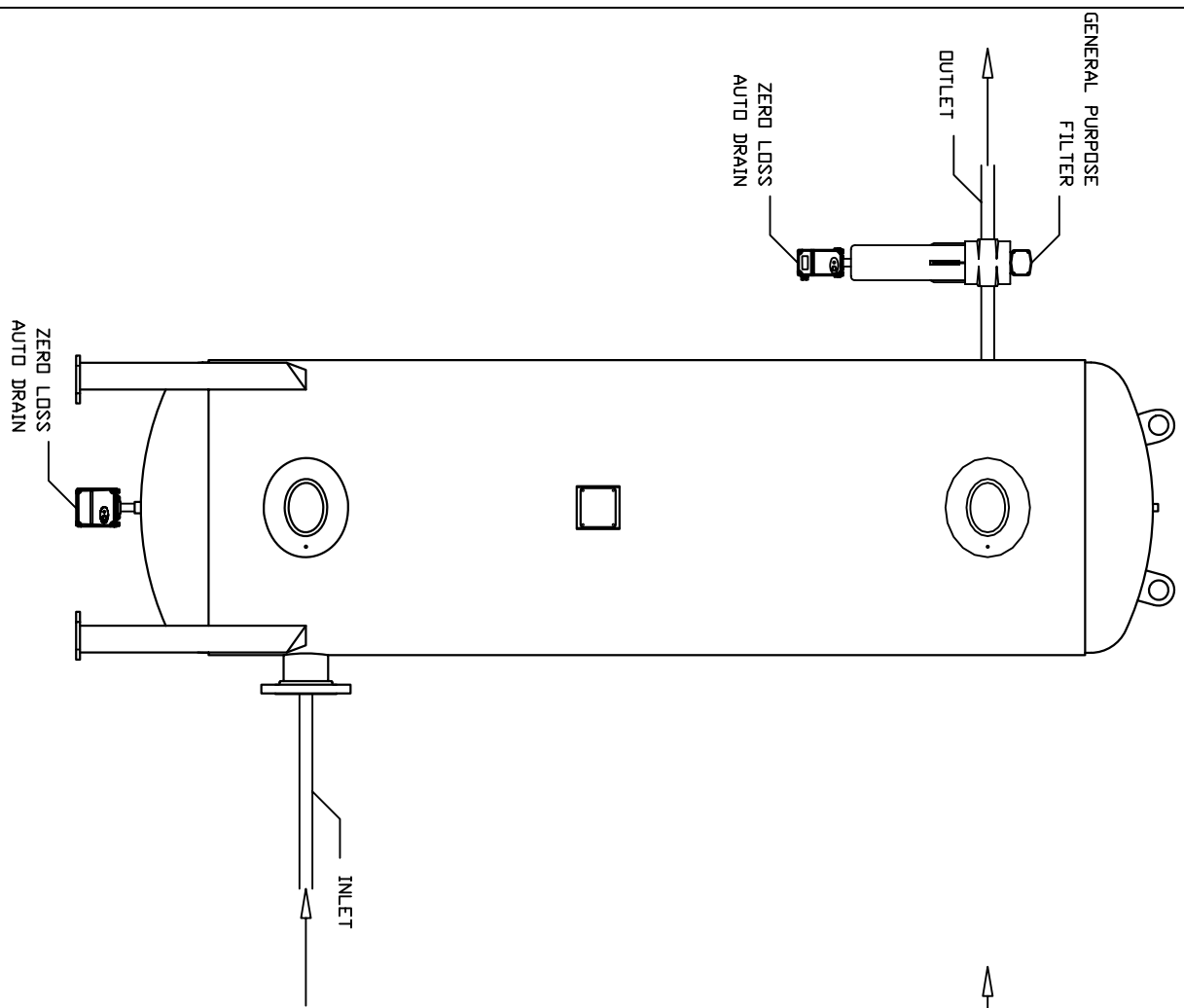

AFTER

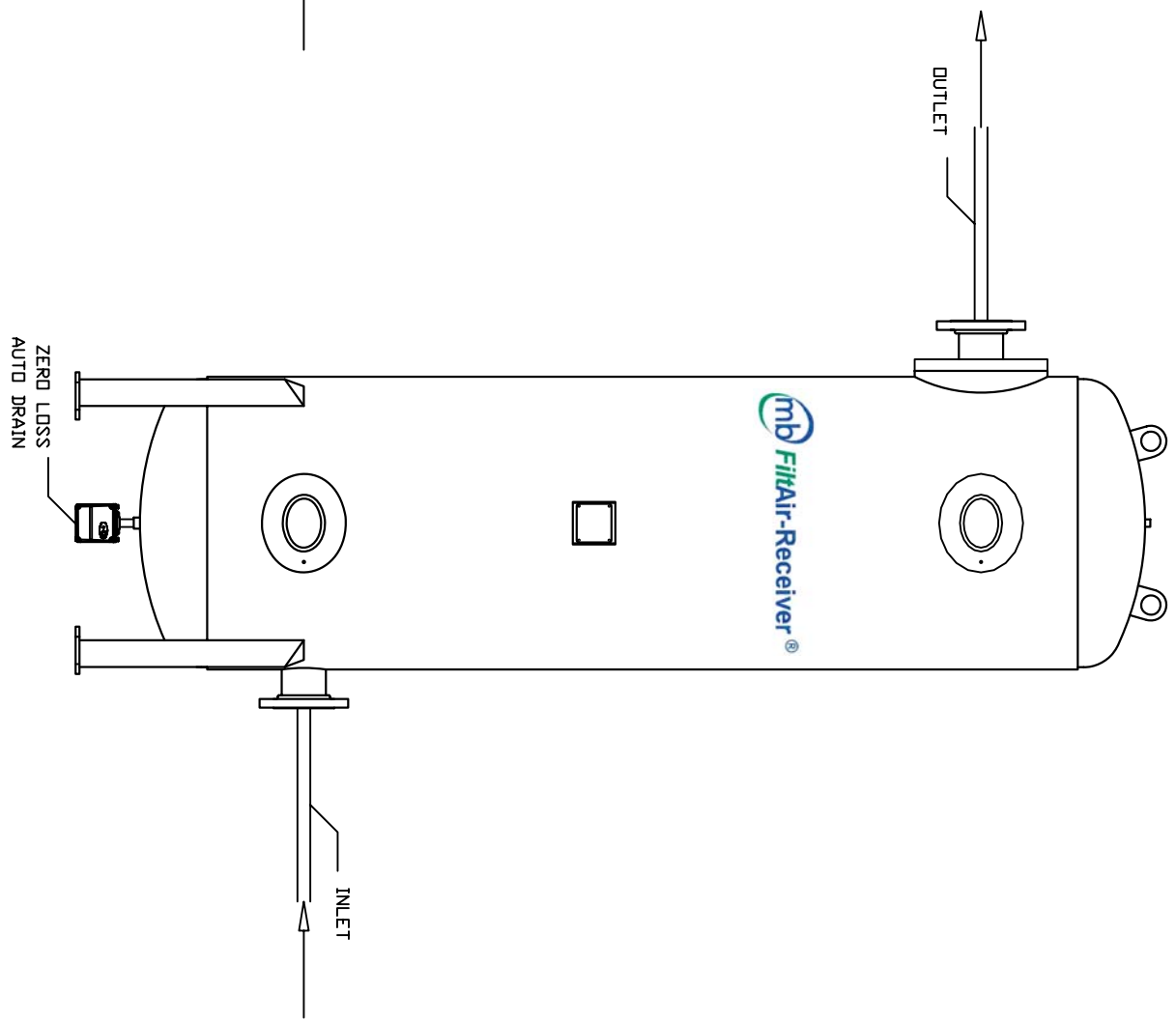

	mb air systems ltd. 149 Glasgow Road Wishaw Lanarkshire ML2 7JL Tel: 01698-355711 Fax: 01698-359299 e-mail: wishaw@air-systems.co.uk	
	FitAir-Receiver 1000	1000 Litres Capacity
Before & After Comparison		Minimum Measure
Page 1 of 2		mb air systems ltd.

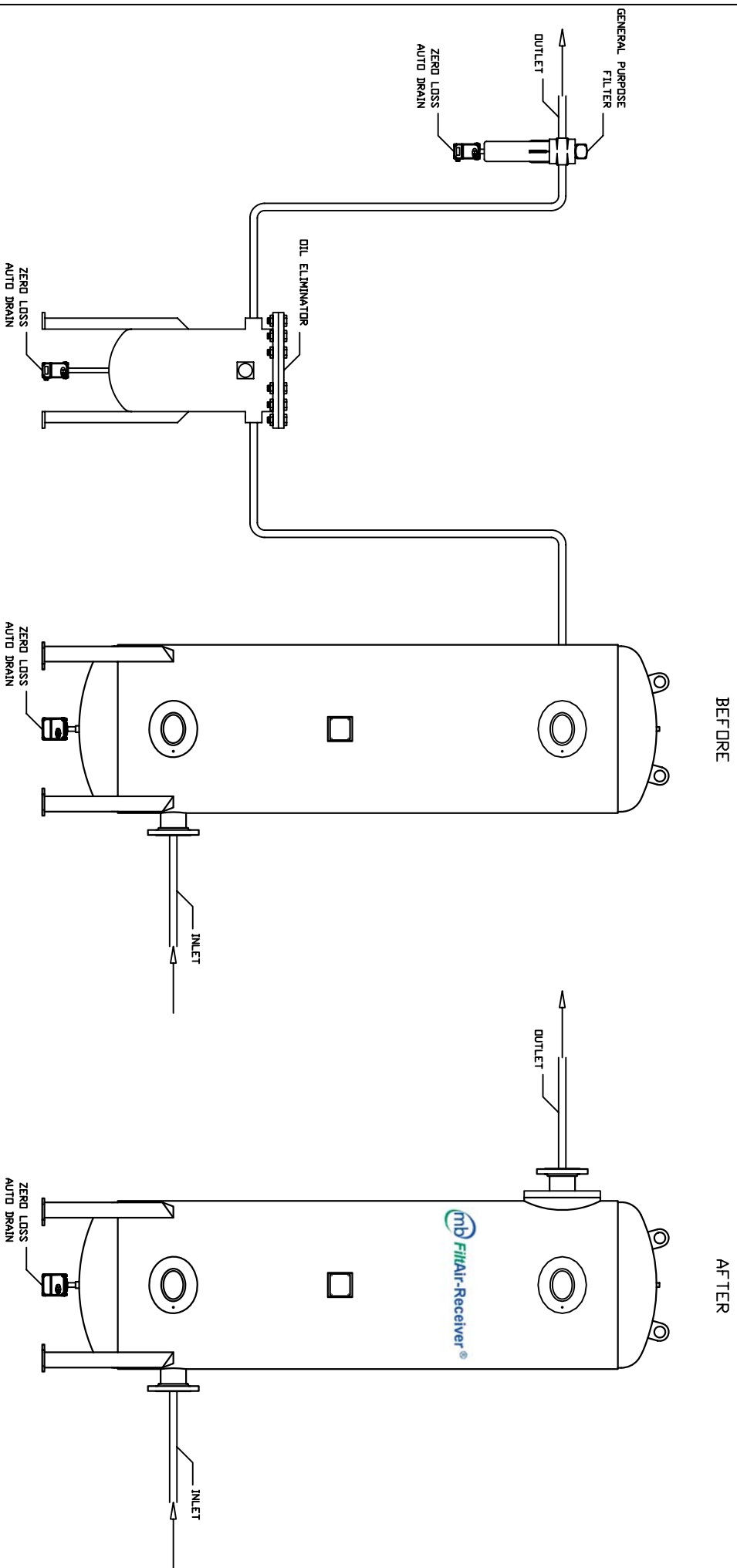

BEFORE

AFTER

	<p>mb air systems ltd. 149 Glasgow Road Wishaw Lanarkshire ML2 7QJ Tel: 01698-355711 Fax: 01698-359299 e-mail: wishaw@air-systems.co.uk</p>	<p>FilAir-Receiver 1000 Before &amp; After Comparison</p>	<p>1000 Litres Capacity Maximum Measure mb air systems ltd.</p>
<p>Page 2 of 2</p>			

BEFORE

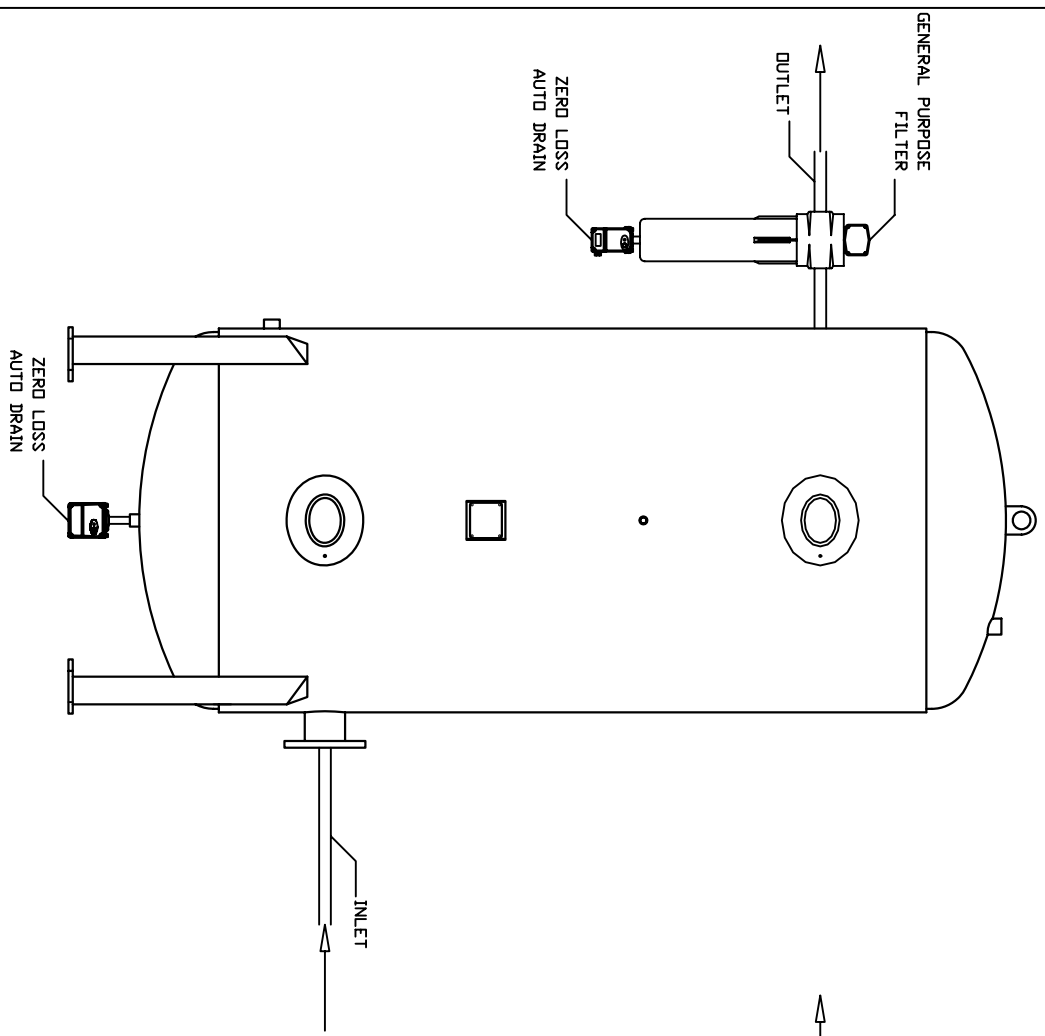

AFTER

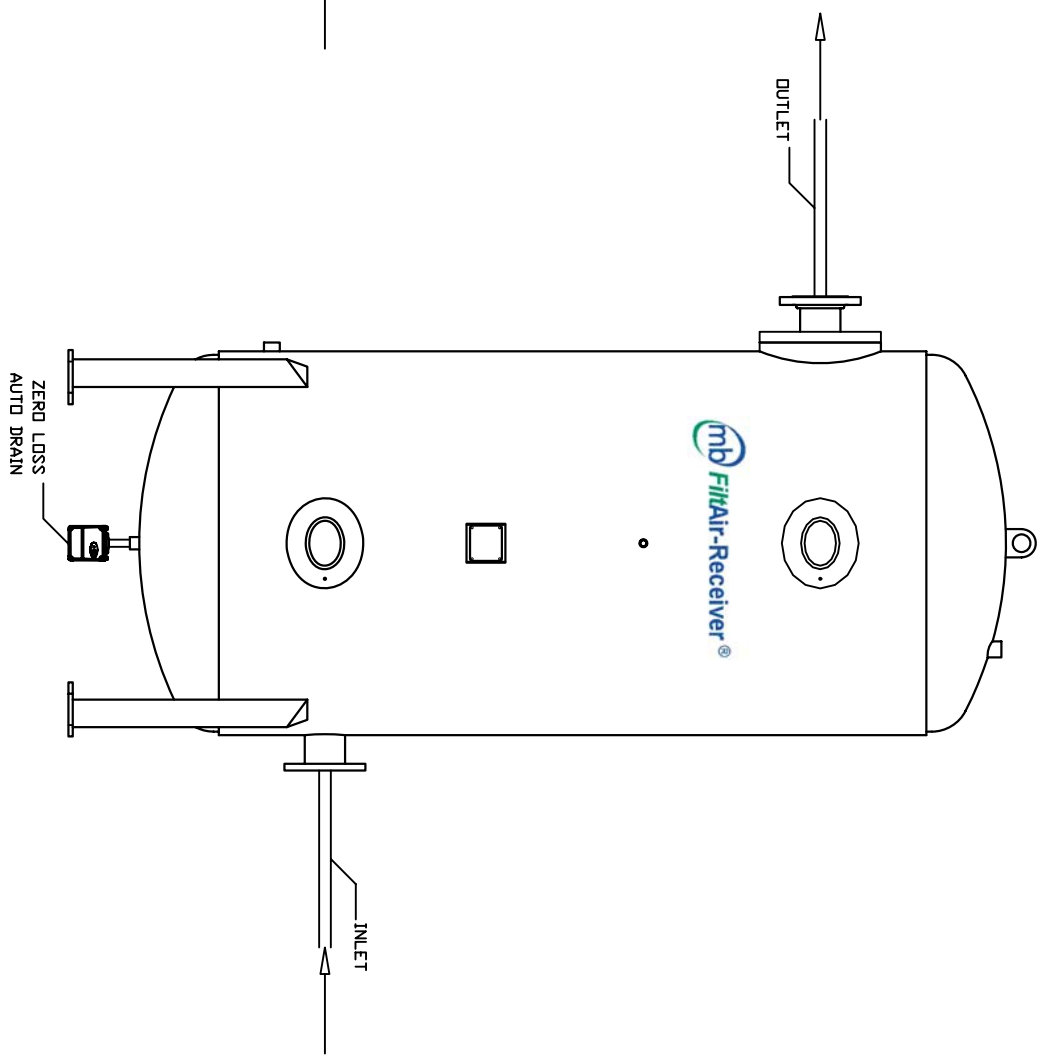

mb air systems ltd.  
149 Glasgow Road  
Wishaw  
Lanarkshire  
ML2 7JL  
Tel: 01698-355711  
Fax: 01698-359299  
e-mail: wishaw@air-systems.co.uk

FilAir-Receiver 2000

2000 Litres Capacity

Before & After Comparison

Minimum Measure

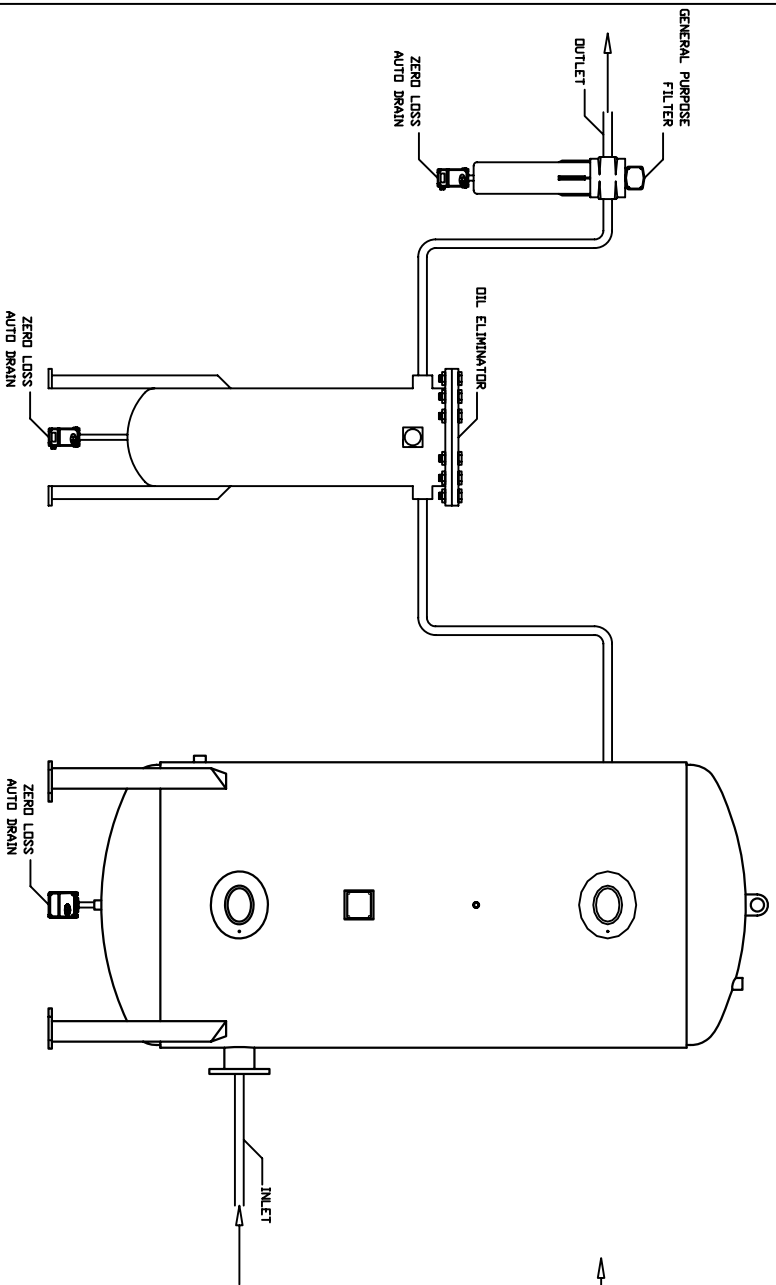

BEFORE

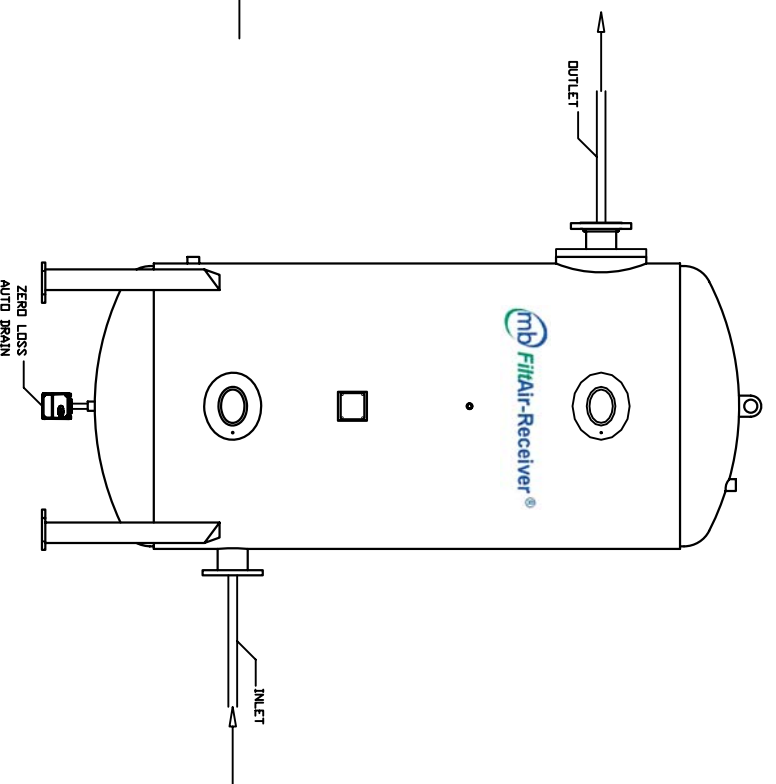

AFTER

	<p>mb air systems ltd. 149 Glasgow Road Wishaw Lanarkshire ML2 7JL Tel: 01698-355711 Fax: 01698-359299 e-mail: wishaw@air-systems.co.uk</p>	<p>Filtair-Receiver 2000</p> <p>Before &amp; After Comparison</p> <p>Page 2 of 2</p>	<p>2000 Litres Capacity</p> <p>Maximum Measure</p> <p>mb air systems ltd.</p>
--	---	--	---

BEFORE

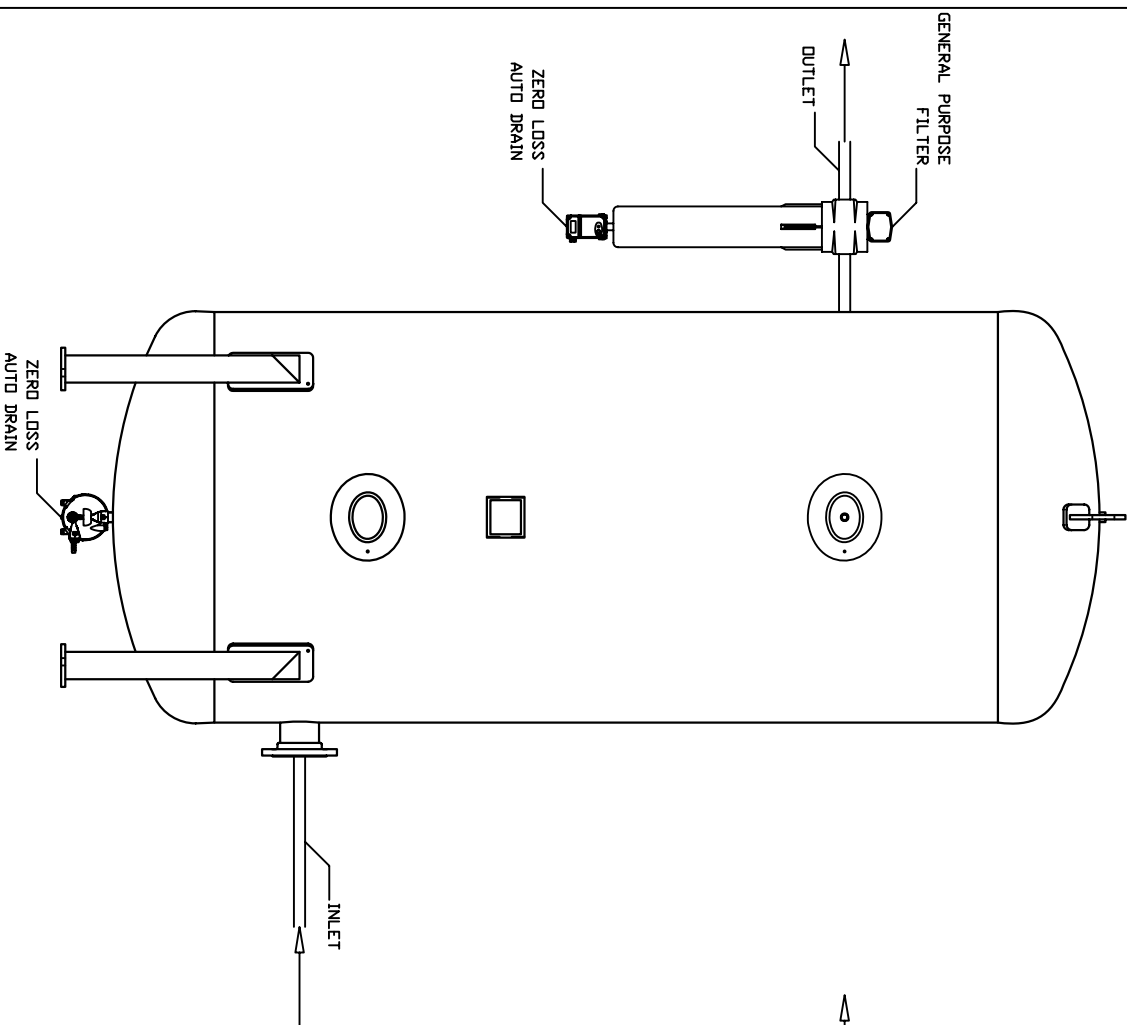

AFTER

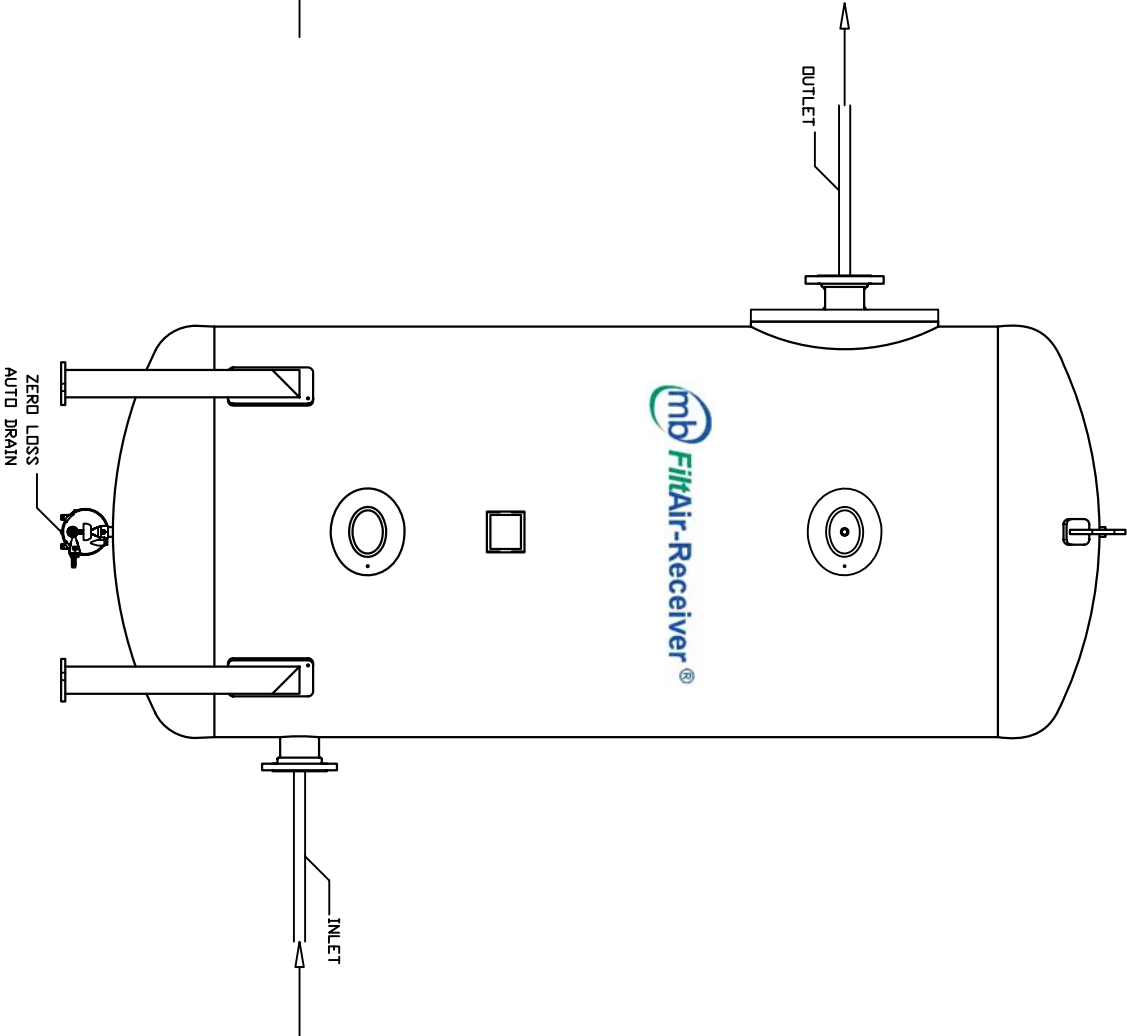

mb air systems ltd.  
 149 Glasgow Road  
 Wilsnaw  
 Lancashire  
 M12 7QJ  
 Tel: 01698-355711  
 Fax: 01698-359299  
 e-mail: [wilsnaw@air-systems.co.uk](mailto:wilsnaw@air-systems.co.uk)

FitAir-Receiver 3000

3000 Litres Capacity

Before & After Comparison

Minimum Measure

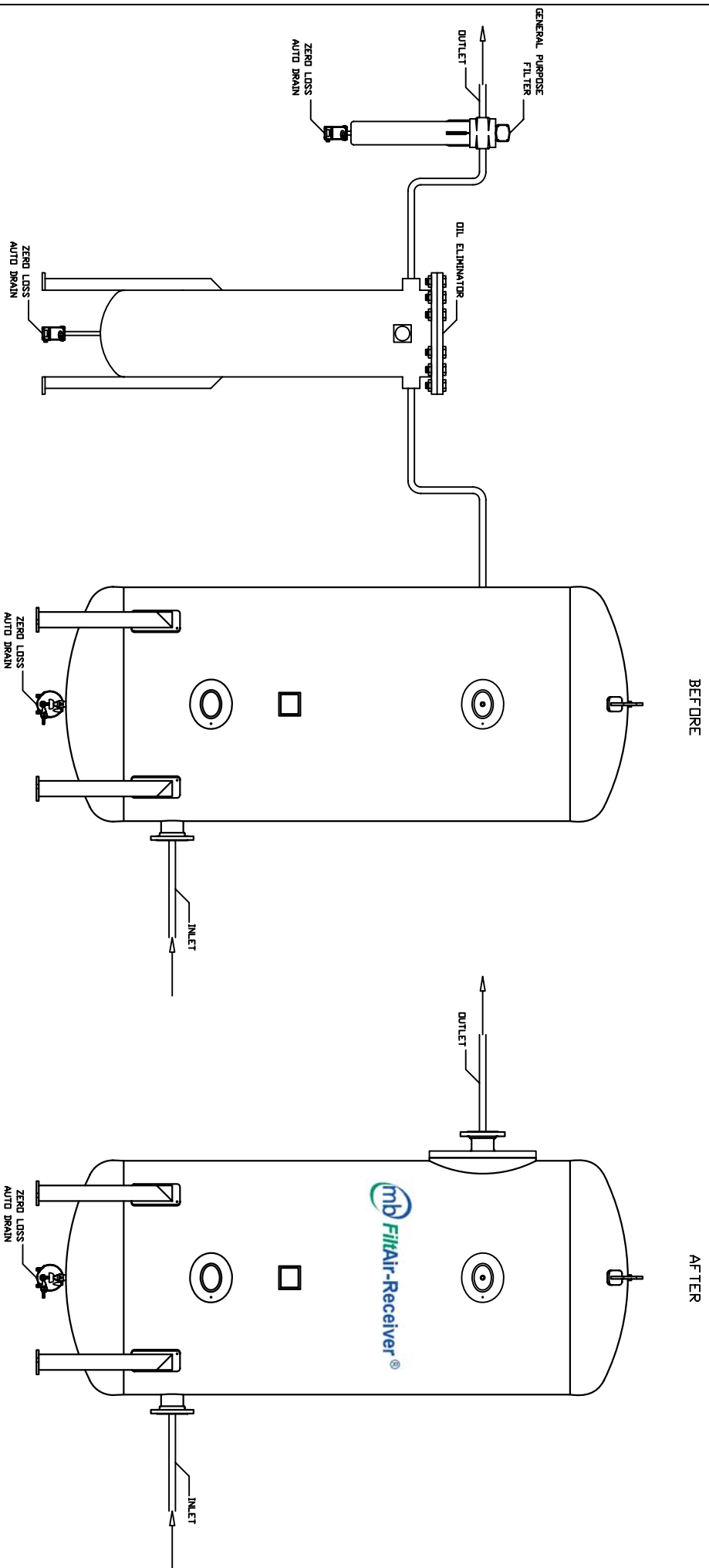

mbd air systems ltd.  
 149 Glasgow Road  
 Wishaw  
 Lanarkshire  
 ML2 7QJ  
 Tel: 01698-355711  
 Fax: 01698-359299  
 e-mail: wishaw@air-systems.co.uk

Filtair-Receiver 3000

3000 Litres Capacity

Before & After Comparison

Maximum Measure

BEFORE

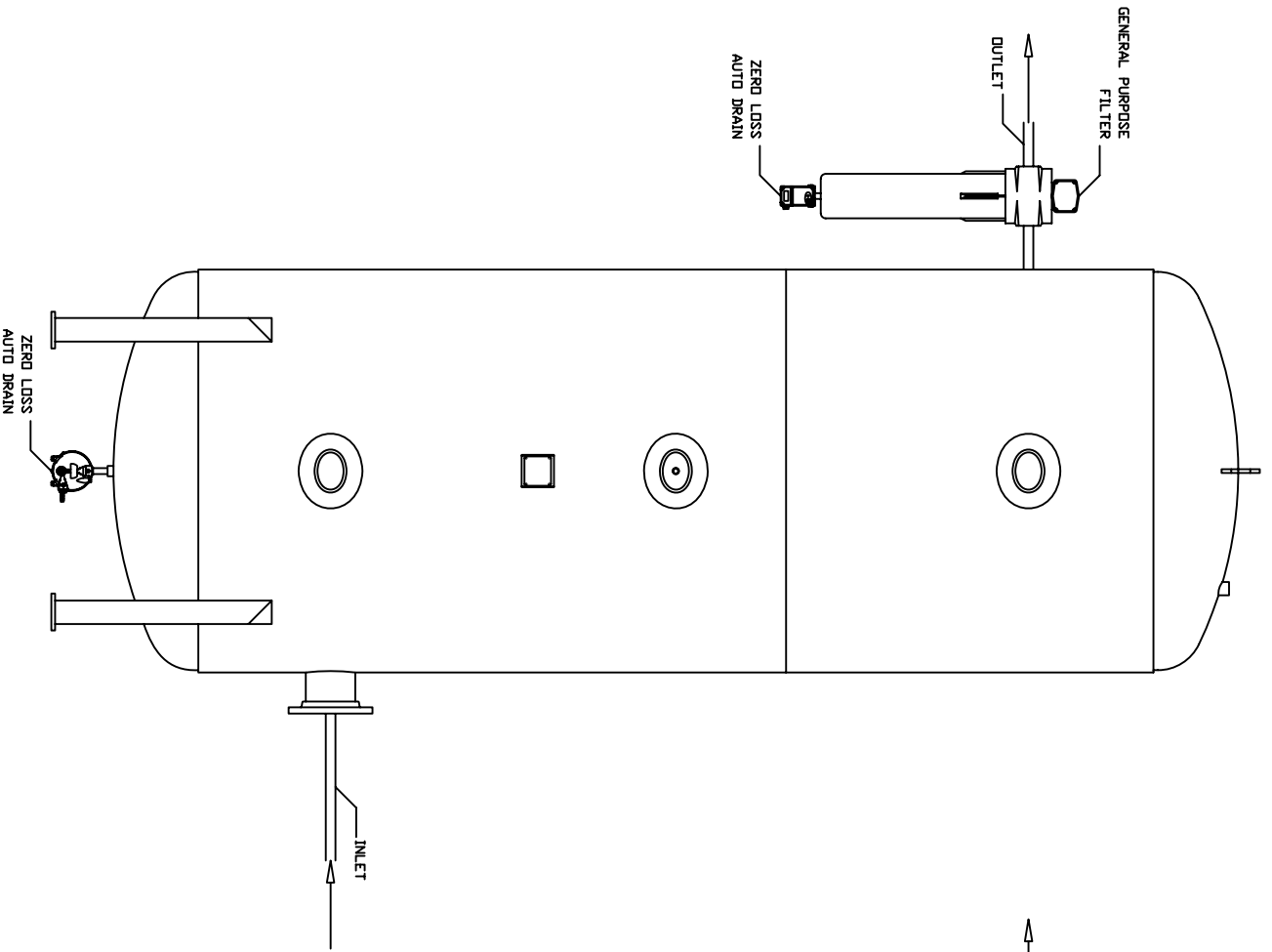

AFTER

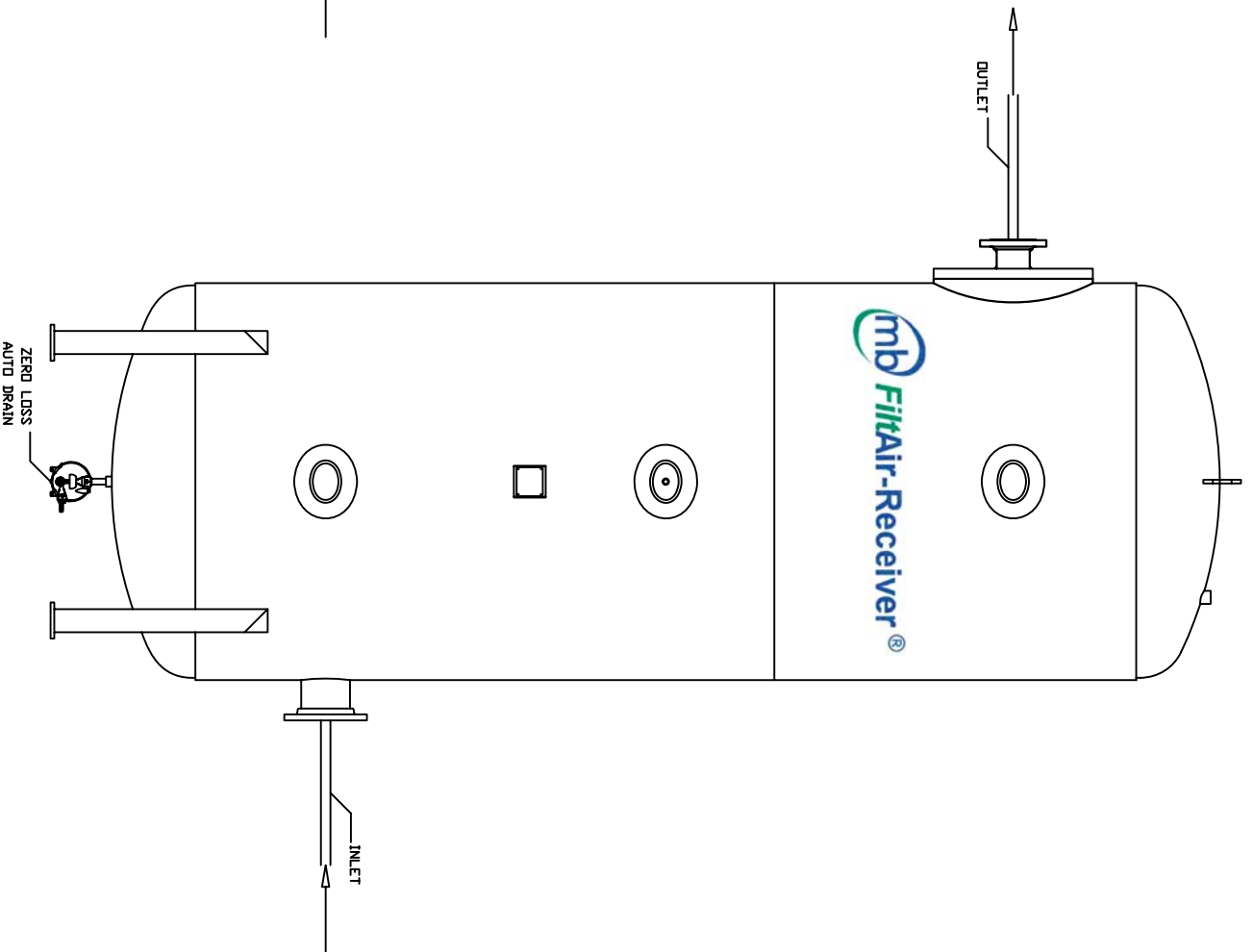

mb air systems ltd.  
 149 Glasgow Road  
 Wishaw  
 Lanarkshire  
 ML2 7QJ  
 Tel: 01698-355711  
 Fax: 01698-359299  
 e-mail: wishaw@air-systems.co.uk

FitAir-Receiver 5000

Before & After Comparison

Page 1 of 2

5000 Litres Capacity

Minimum Measure

mb air systems ltd.

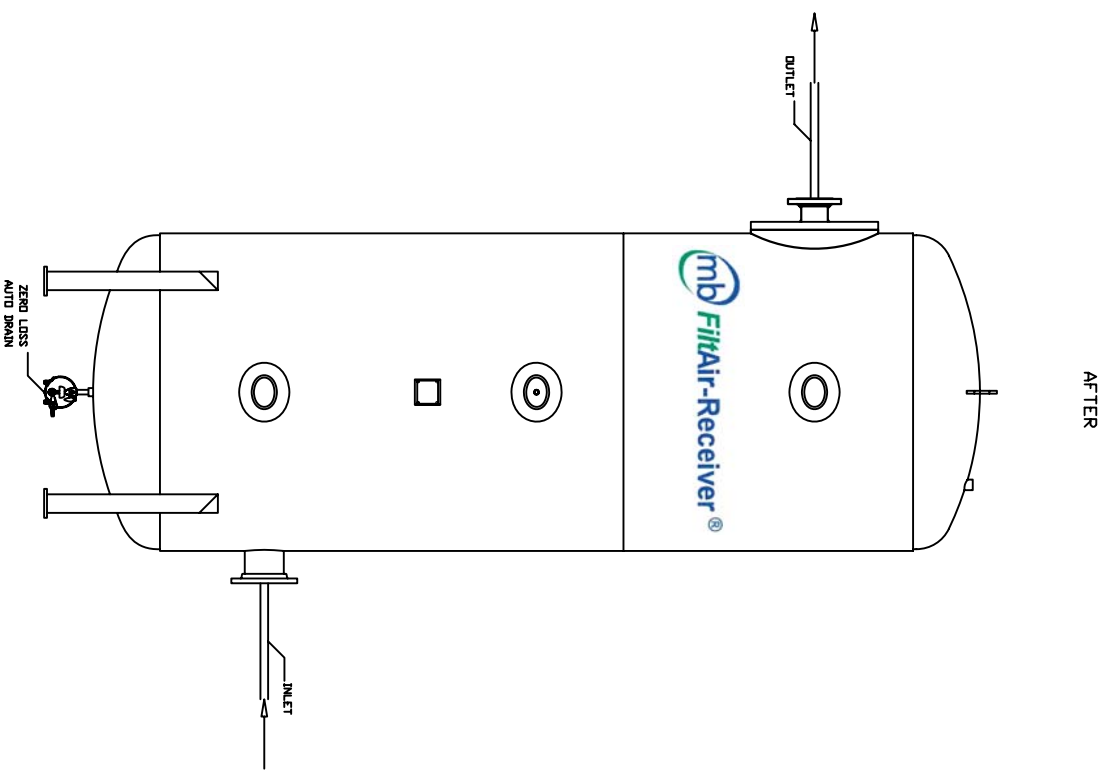
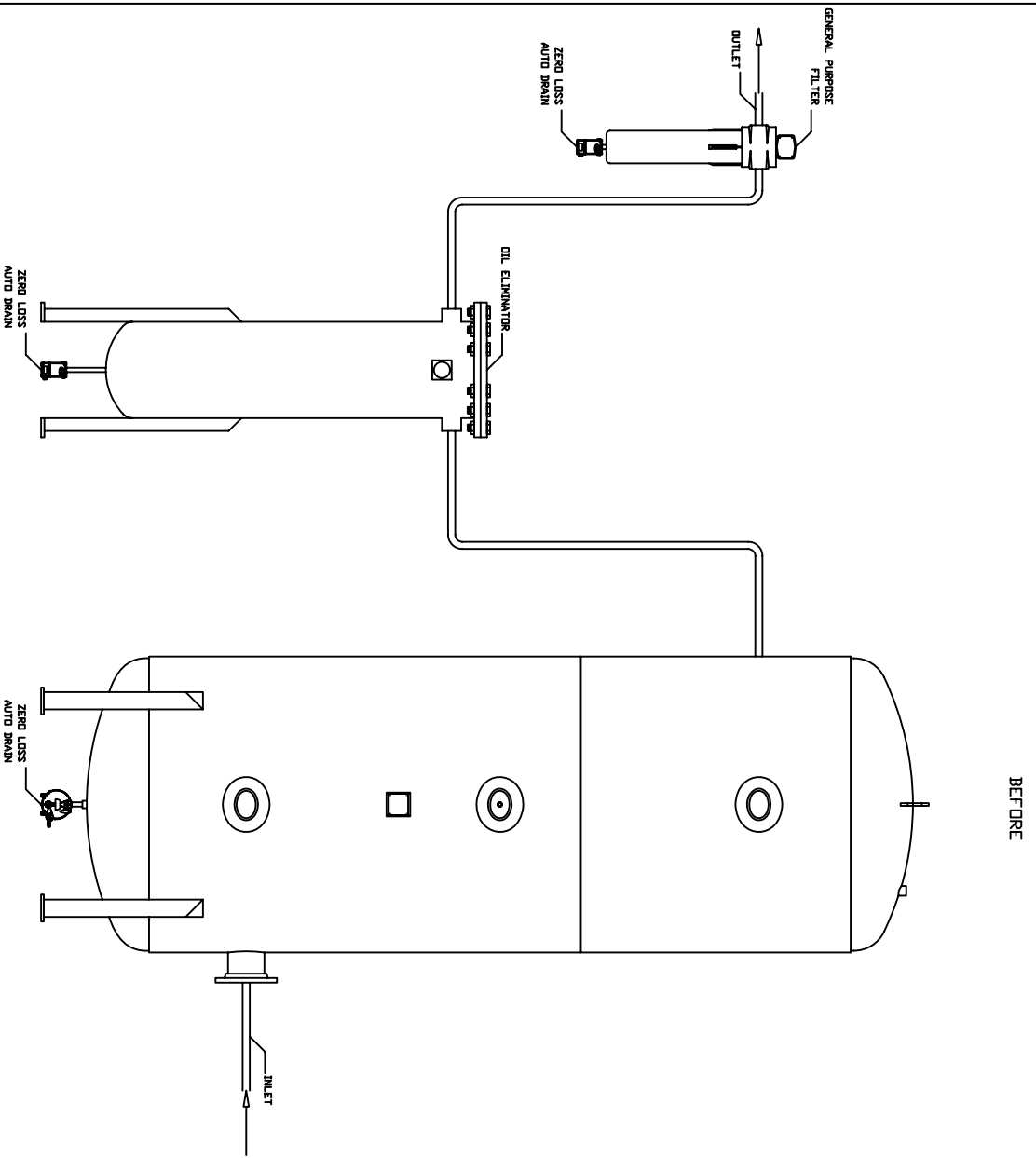

mb air systems ltd.  
 149 Glasgow Road  
 Wilsnaw  
 Lancashire  
 M12 7QJ  
 Tel: 01698-355711  
 Fax: 01698-359299  
 e-mail: wilsnaw@air-systems.co.uk

Filtair-Receiver 5000  
 Before & After Comparison

5000 Litres Capacity  
 Maximum Measure  
 mb air systems ltd.

